

Automotive Ethernet Box Installation

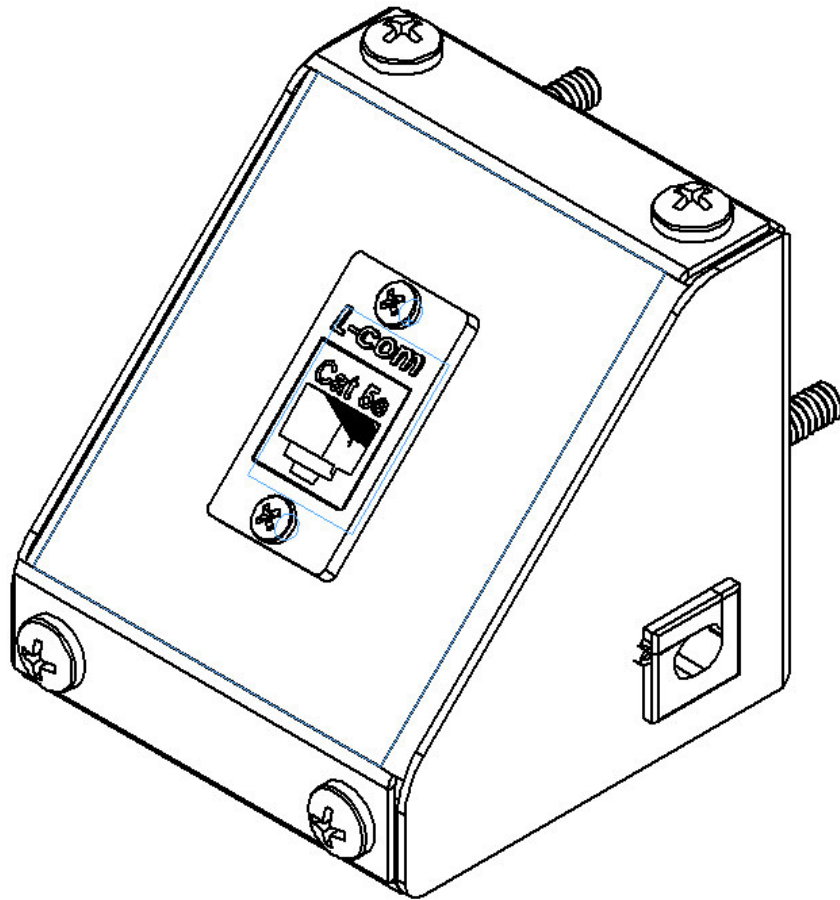

Automotive Ethernet Box Installation



Ethernet Box Specifications:

- Stainless Steel housing
- Female RJ45 Ethernet Jack

Tools Required:

- Scribe or similar to mark mounting hole locations for drilling
- Drill and 1/8" diameter drill bit
- Safety glasses
- Phillips head and Flat head screwdrivers

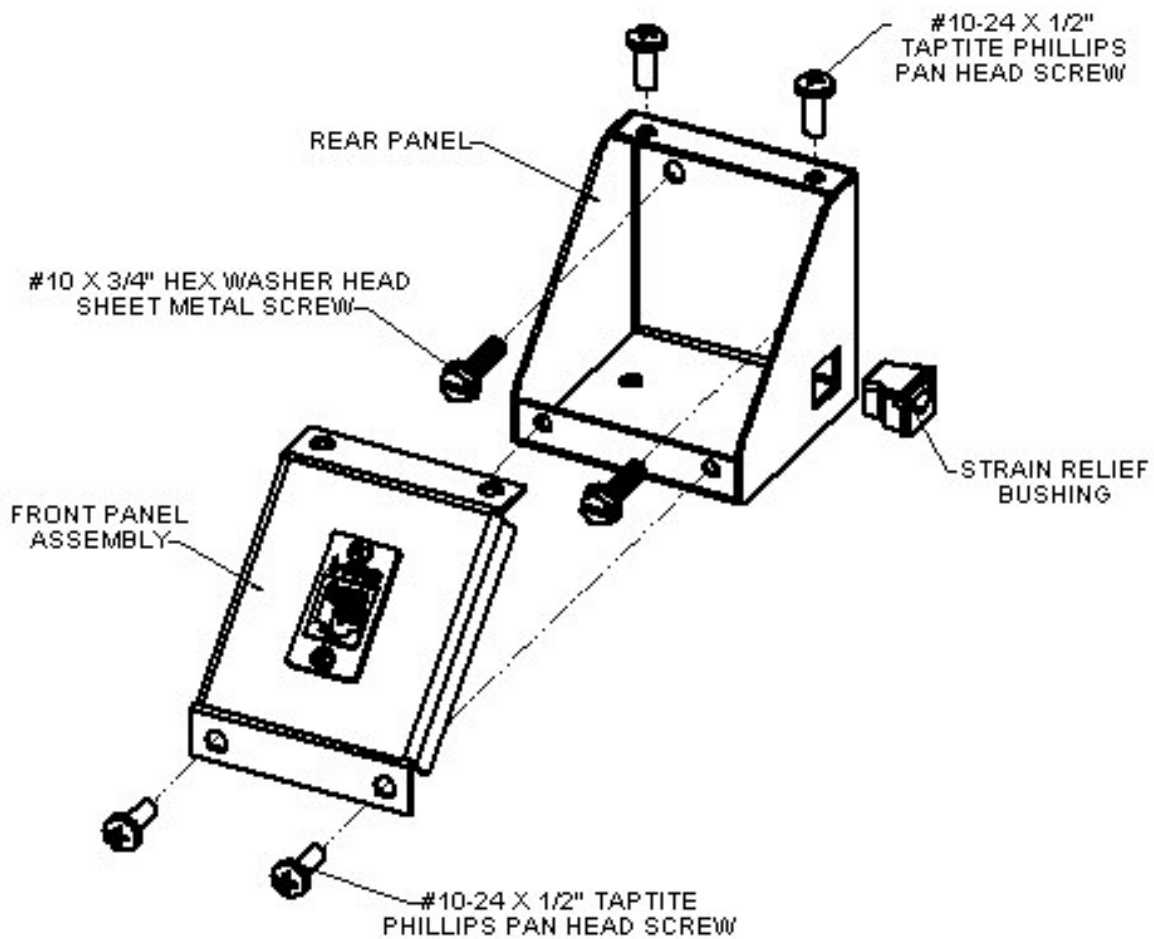

Automotive Ethernet Box Installation

Installation Steps

1. Locate Rear Panel where desired
2. Mark and drill (2) holes 1/2" deep in rear or bottom using a 1/8" diameter drill bit (safety glasses must be worn when drilling)
3. Mount Rear Panel using (2) included #10 x 3/4" hex washer head sheet metal screws
4. Thread male RJ45 Ethernet cable connector (not provided) through included strain relief bushing and square cutout in side of Rear Panel
5. Plug male RJ45 Ethernet cable connector into rear of Ethernet RJ45 jack (mounted to Front Panel Assembly)
6. Install strain relief bushing into square cutout in side of Rear Panel
7. Bolt Front Panel Assembly to Rear Panel using (4) included #10-24 x 1/2" Taprite Phillips head screws (2) in top and (2) in front as shown



Automotive Ethernet Box Installation

Making Workspace Work™ is a trademark of Lista International Corporation.

Document Number: MD071A3 Rev 0

Print Date: December 2010

These instructions and other assembly instructions may be found on Lista International Corporation's web site, <http://www.listaintl.com>. For questions or Technical Support, please call 1-800-722-3020

This manual is proprietary information of Lista International Corporation. Unauthorized reproduction of any portion of this manual is prohibited without the written consent of Lista International Corporation. The material in this manual is for informational purposes only. It is subject to change without notice. Lista International Corporation assumes no responsibility for any typographical errors contained in this manual.

Lista International Corporation
106 Lowland Street
Holliston, MA 01746-2094
Toll Free: (800) 722-3020
Phone: (508) 429-1350
E-mail: sales@listaintl.com
Web: <http://www.listaintl.com/>

ISO 9001 Certified

© 2010 Lista International Corporation
All rights reserved.